

**LUCIDA**<sup>®</sup>  
SURFACES

**Max**CORE™

**Terra**CORE™

**Deco**CORE™

**Cl**iCORE™

**Mono**CORE™

**SPC FLOORING**

# Product Information

- » Installation Guide
- » Care & Maintenance
- » Warranty Information

# Part 1. Installation Guide

Thank you for choosing a Lucida product. When properly installed and cared for, your new flooring will be easy to maintain and keep its great look for years.

Please read all the instructions before you begin the installation. Improper installation will void warranty.

## **WARNING!**

Your old Floors may contain Asbestos!

DO NOT SAND, DRY SWEEP, DRY SCRAPE, DRILL, SAW, BEAD-BLAST OR MECHANICALLY CHIP OR PULVERIZE PREVIOUSLY INSTALLED EXISTING RESILIENT FLOORING, BACKING, LINING FELT, ASPHALTIC "CUTBACK" ADHESIVES OR OTHER ADHESIVES, AS THESE PRODUCTS MAY CONTAIN ASBESTOS FIBERS AND/OR CRYSTALLINE SILICA.

- Avoid creating dust when removing existing flooring and adhesive. Inhalation of such dust is a cancer and respiratory tract hazard. Smoking by individuals exposed to asbestos fibers greatly increases the risk of serious bodily harm.

- Unless positively certain that the product is a non-asbestos-containing material, you must presume it contains asbestos. Regulations may require that the material be tested to determine asbestos content and may govern the removal and disposal of material. See current edition of the Resilient Floor Covering Institute (RFCI) publication Recommended Work Practices for Removal of Resilient Floor Coverings for detailed information and instructions on removing all resilient covering structures.

## **TOOLS REQUIRED:**

Spacers, rubber mallet, ruler, pencil, tape measure, utility knife.

## **I. GENERAL PREPARATIONS**

- It is preferable to lay boards following the direction of the main source of light.
- For the best result, make sure to always work from 2 to 3 cartons at a time, mixing the planks during the installation.
- Prior to installation, inspect material in daylight for visible faults/damage. No claims on surface defects will be accepted after installation.
- Check if subfloor/site conditions comply with the specifications described below. If you are not satisfied, do not install, and contact your supplier.
- Flooring products can be damaged by rough handling before installation. Exercise care when handling and transporting these products. Store, transport and handle the flooring planks in a manner to prevent any damage. Store cartons flat, never on edge.
- Flooring products can be heavy and bulky. Always use proper lifting techniques when handling these products. Whenever possible, make use of material-handling equipment such as dollies or material carts. Never lift more than you can safely handle.
- Calculate the room surface prior to installation and plan an extra 5% of flooring for cutting waste.
- The environment where the flooring is to be installed is critically important for successful installation and continued performance of the flooring products. The flooring is intended to be installed in interior locations only and the space must meet climate and structural requirements as well.
- Flooring should only be installed in temperature-controlled environments. It is necessary to maintain a constant temperature before, during and after the installation.

- Portable heaters are not recommended as they may not heat the room and subfloor sufficiently. Kerosene heaters should never be used.
- This product does not need acclimation.
- For floor surfaces exceeding 6400ft<sup>2</sup> (620m<sup>2</sup>) and/or lengths exceeding 80 lineal feet (25m), use expansion moldings.

## II. SUBFLOOR INFORMATION

- Inspect your subfloor before you begin, it must be clean, dry and level to 3/16" (5mm) within 10 feet (3 meters). Substrates must be free from excessive moisture or alkali. Remove dirt, paint, varnish, wax, oils, solvents, any foreign matter and contaminates.
- Do not use products containing petroleum, solvents or citrus oils to prepare substrates as they can cause staining and expansion of the new flooring.
- Although this floor is waterproof, it is not aimed to be used as a moisture barrier. The subfloor must be dry. Moisture emission from subfloor cannot exceed 3 lbs. per 1,000 sq. ft. per 24 hours as measured with the calcium chloride test in accordance with ASTM F1869-04 or ASTM F2170 In-Situ Relative Humidity not to exceed 75%.
- This product is also not to be installed in areas that have a risk of flooding or permanent wetness such as hot tubs, saunas or outdoor areas.
- sq. ft. per 24 hours as measured with the calcium chloride test in accordance with ASTM F1869-04 or ASTM F2170 In-Situ Relative Humidity not to exceed 75%.
- Turn the heat off for 24 hours before, during and 24 hours after installation when installing over radiant heated subfloors. Failure to turn the heat off may result in significantly shortened working time of the adhesive.
- Make sure that the temperature in the room is at least 60°F (15°C) during installation.
- Floor temperature must not exceed 85°F (30°C).
- Once the installation has been completed, the heating system should be turned on and increased gradually (5 degree increments) until returning to normal operating conditions.
- Refer to the radiant heat system's manufacturer recommendations for additional guidance.
- Failure to strictly follow adhesive manufacturer's guidelines may result in failure and void the warranty.

### RADIANT HEAT NOTICE

Radiant heat systems must have a minimum of 1/2" separation from the product. The maximum operating temperature should never exceed 85°F [30°C].

- Use of an in-floor temperature sensor is recommended to avoid overheating.
- In-floor Radiant Heat: Flooring can be installed over 1/2" embedded radiant heat using the floating or glue down method.
- Before installing over newly constructed radiant heat systems, operate the system at maximum capacity to force any residual moisture from the cementitious topping of the radiant heat system. Moisture emission from subfloor cannot exceed 3 lbs. per 1,000

### ELECTRIC HEATING MATS NOTICE

Electric heating mats that are not embedded into the subfloor are not recommended for use below the floors.

- Using electric heating mats that are not embedded and applied directly underneath the floors could void the warranty for your floor in case of failure.
- It is best to install the flooring over embedded radiant floor heating systems and adhere to the guidelines listed above.

## WOOD SUBFLOORS

- If this flooring is intended to be installed over an existing wooden floor, it is recommended to repair any loose boards or squeaks before you begin the installation. Nail or screw every 6" (15 cm) along joists to avoid squeaking.
- Basements and crawl spaces must be dry. Use of a 6-mil black polyethylene is required to cover 100% of the crawl space earth.
- We recommend laying the product on wooden floors perpendicular to the existing floorboards.
- All other subfloors - Plywood, OSB, particleboard, chipboard, wafer board, etc. must be structurally sound and must be installed following their manufacturer's recommendations.

## CONCRETE SUBFLOORS

- Floors must be fully cured, at least 60 days old, smooth, permanently dry, clean, and free of all foreign material such as dust, wax, solvents, paint, grease, oils, and old adhesive residue. Curing agents and hardeners could cause bonding failure and should not be used.
- Depressions, deep grooves, expansion joints and other subfloor imperfections must be filled with patching & leveling compound.
- Concrete substrates must be flat within 1/8 of an inch (3mm) within a 6-foot (2 meters) radius, or 3/16 of an inch (5mm) within a 10-foot radius (3 meters). The substrate should not slope more than 1 inch (2.5cm) per 6 feet (2 meters) in any direction.
- Moisture and alkalinity tests should be performed on all concrete substrates regardless of grade level or age of slab. Perform either ASTM F2170 In-Situ Relative

Humidity (RH) test or ASTM F1869 Calcium Chloride Moisture Test (MVER: Moisture Vapor Emission Rating). Perform pH test per ASTM F710 to determine alkalinity of the slab.

- Moisture emission from subfloor cannot exceed 3 lbs. per 1,000 sq. ft. per 24 hours as measured with the calcium chloride test in accordance with ASTM F1869-04 or ASTM F2170 In-Situ Relative Humidity not to exceed 75%. If results are higher than referenced, then a minimum 6mil polyethylene plastic moisture barrier must be applied.
- Please refer to the Limited Warranty section regarding water damage coverage.

## EXISTING FLOORS

- The flooring can be installed over most existing hard surface floor coverings, provided that the existing floor surface is clean, flat, dry, securely fastened, and structurally sound.
- Existing sheet vinyl floors should not be heavily cushioned and not exceed more than one layer in thickness. Soft underlayment and soft substrates will diminish the products' inherent strength in resisting indentations.
- Never use solvents or citrus adhesive removers to remove old adhesive residue. Solvent residue left in and on the subfloor may affect the new floor covering.

## DO NOT INSTALL OVER

- Hardwood flooring / wood subfloors that lay directly on concrete or over dimensional lumber or plywood used over concrete.
- Any type of carpet.
- Existing cushion-backed vinyl flooring.
- Floating floor of any type, loose lay, and perimeter-fastened sheet vinyl.

---

## III. INSTALLATION

- Remove baseboard, quarter-round moldings, wall base, appliances and furniture from room. For best results, door trim should be under-cut to allow flooring to move freely without being pinched. After preparation work, sweep and vacuum the entire work area to remove all dust and debris.
- With a floating floor you must always ensure you leave a 1/4" (6mm) gap between planks and walls, pipes, pillars, stairs, etc. These gaps will be covered with trim moldings after the floor is installed. Tip: When installing around pipes, drill the holes 1/2" (12mm) larger than the diameter of the pipes.

- Whenever possible, plan the layout so that the joints in the planks do not fall on top of joints or seams in the existing substrate. The end joints of the planks should be staggered a minimum of 8" (20.32 cm) apart. Do not install over expansion joints. Avoid installing pieces shorter than 12"(30 cm) at beginning or end of rows.
- Do not install your kitchen cabinets directly over your floor. Spacers should be placed between the cabinets and the floor to ensure quality of installation.
- Decide the installation direction. It is recommended to install the planks lengthwise and parallel to the main light direction.
- Measure the area to be installed: The board width of the last row shall not be less than 2" (50mm). If so, adjust the width of the first row to be installed. In narrow hallways, it is recommended to install the floor parallel to the length of the hall.

#### IV. FINISHING THE INSTALLATION

- Replace molding or wall base, allowing slight clearance between the molding and the planks.
- Nail the molding to the wall surface, not through the flooring.
- At doorways and at other areas where the flooring planks may meet other flooring surfaces, it is preferable to use a "T" molding, or similar, to cover the exposed edge but not pinch the planks. Leave a small gap between the planks and the adjoining surface.
- After installation, make sure that the flooring is not be exposed to temperatures less than 0°F (-15°C) or greater than 140°F (60°C).

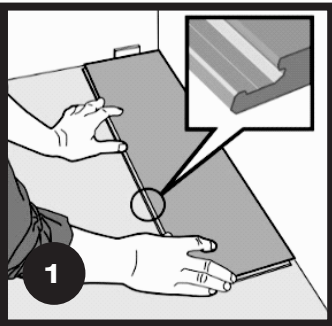

After thoroughly cleaning the subfloor, you should begin laying from left to right. Position the first plank so that grooved edge is facing you. Use a spacer to set a 1/4" (6mm) gap between flooring and the wall.

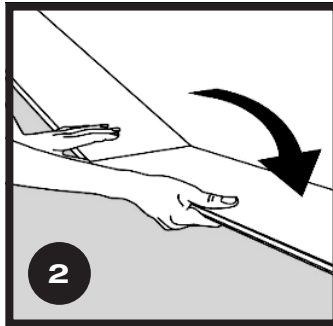

Second plank, first row. Drop the plank of short side first, and then gently tap down the end with a rubber mallet so it firmly locks into the previous plank until both are at the same height. Make sure both planks are perfectly aligned. Continue installing the first row until you reach the wall on the right.

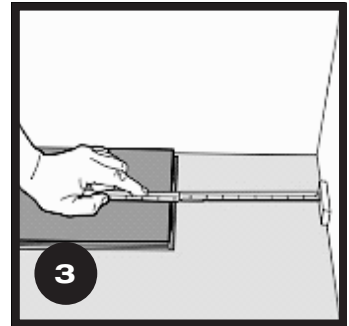

At the end of the first row, leave an expansion gap of 1/4" (6mm) to the wall and measure the length of the last plank to fit.

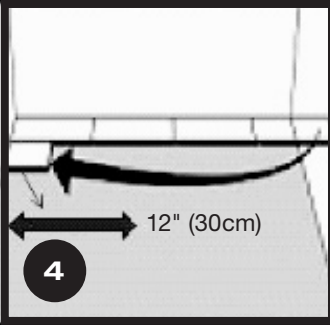

Start the second row with the leftover cut part of the last plank of the previous row. This small plank should measure at least 12" (30cm). Otherwise, cut a new plank in half and use it to begin the second row. Whenever practical, use the piece cut from the preceding row to start the next row.

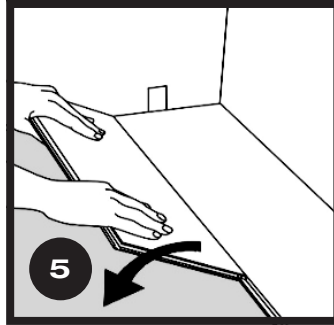

Roll the SPC plank against the previous row and push it downwards.

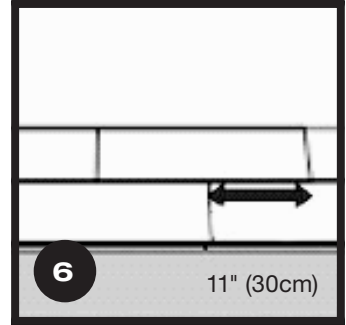

Make sure that end joints of all planks should be staggered 30cm at least or more.

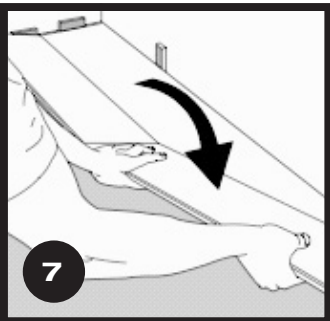

Click the short side and place it tight to the short end of the left plank.

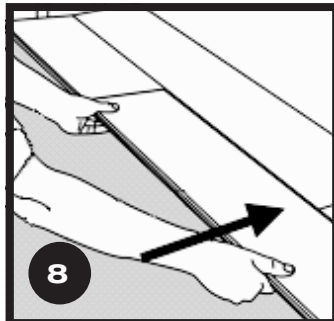

Drop the long side of the plank into the previous row and place it tight to the previous plank with an angle of 30 degrees, and gently tap on the end with a rubber mallet so it firmly locks into the previous plank until both are at the same height. Make sure both planks are perfectly aligned.

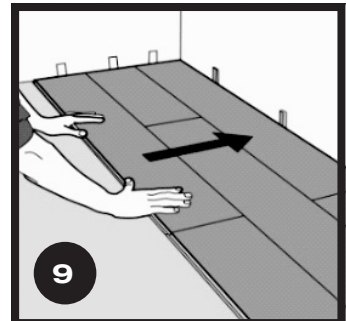

After the first 2-3 rows of planks are installed, they should be checked with a string line to ensure that rows are still running straight. If they are not, it could be that the starting wall has some irregularities that caused bowing in the installation.

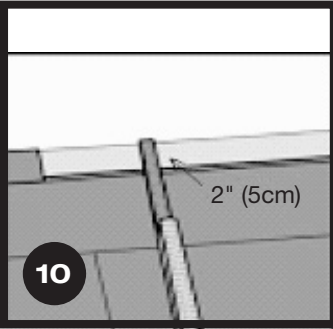

The last row of floorboards should be at least 2" (5cm) wide. If needed reduce the width of first row.

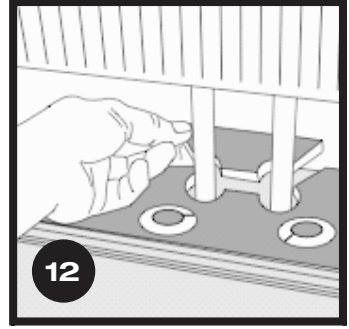
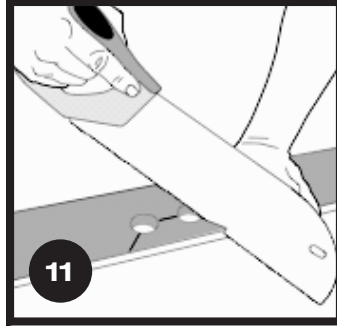

When drilling holes around a vertical object, make sure the holes are bigger than the width of object, cutting the small area and filling into the inner side.

---

## V. DISASSEMBLING

Separate the whole row by lifting it up delicately at an angle. To separate the planks, leave them flat on the ground and slide them apart. If planks do not

separate easy, you can slightly lift up the planks (5°) when sliding them apart.

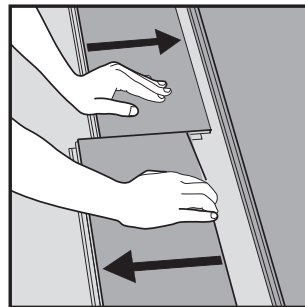
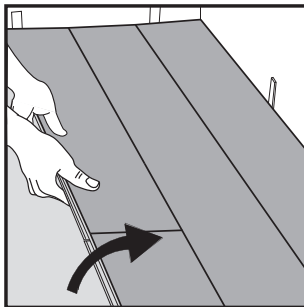

## Part 2. CARE & MAINTENANCE GUIDE

This is a comprehensive maintenance guide for MaxCore flooring products from LUCIDA SURFACES. Following this guide is mandatory in order to validate your Exclusive Warranty by LUCIDA SURFACES in both residential and commercial applications. Contact LUCIDA SURFACES regarding any questions or concerns you may have.

### BEFORE & AFTER INSTALLATION

LUCIDA SURFACES flooring products were intelligently designed and manufactured to provide robust and low maintenance flooring systems for both residential and commercial applications. Following this guide is mandatory to validate the Exclusive Warranty and to guarantee a satisfactory experience.

- Before and after installation, ensure that your flooring remains within the specified suitable environmental conditions outlined in the installation guide for your product.

- For installations using adhesive wait 5 days before using a wet mop to clean your floors to allow the adhesive to fully bond to the sub floor and flooring.
- Immediately after installation, use a damp cloth to wipe up any excessive adhesive before it is allowed to cure. Adhesive that has dried can be removed using a plastic scraper; do not use sharp or metallic scrapers.
- After installation, dry mop or vacuum the installation area to remove debris and dirt.
- Make sure that the floors are adequately protected during installation if other trades are working within the environment. Damage caused by workers within the installation area is not covered under warranty.
- It is recommended for residential, and mandatory for commercial applications that a protective floor matting is used in entrances. Do not use rubber backed matting as it is known to discolor all-wear layers and is not covered under warranty.
- Immediately wipe off chemicals that can discolor and damage the flooring.



## MAINTENANCE & CLEANING

Cleaning your LUCIDA SURFACES MaxCore Floorings is a breeze as all of our products are manufactured with a robust polyurethane coated wear layer. Please follow the cleaning guide outlined below. Only use cleaners that are provided as examples.

- Only use a neutral PH cleaner to clean your floors such as ZEP Neutral Floor Cleaner or a mild dish detergent similar to Dawn. Use of stronger detergents such as Pine Sol is acceptable provided that the floors are followed up with a rinse to remove any residue. Failure to rinse floors may cause a buildup of detergent and may dull the finish of your floor (which is not covered under warranty). Cleaners only need to be used sparingly; more is not always better.
- Use of abrasive and harsh cleaners such as bleach or solvents will void the wear warranty. Only use mops with non-abrasive fibers to clean Sweep or vacuum daily using soft bristle attachments.
- Clean up spills and excessive liquids immediately.
- Damp mop as needed and use cleaners recommended for vinyl flooring.
- Use proper floor protection devices such as felt protectors under furniture.
- Place a walk-off mat at outside entrances to reduce the amount of dirt brought into your home. Do not use mats with a latex or rubber backing since these backings can cause permanent discoloration.
- Do not use abrasive cleaners, bleach or wax to maintain the floor.
- Do not drag or slide heavy objects across the floor

## PREVENTIVE CARE

- Felt pads must be placed under the legs of all furniture such as couches, tables, and chairs. This will protect your floor from damage and allows furniture to effortlessly glide over the flooring. Damage to the surface of flooring from dragging objects across it is not covered by warranty.
- Heavy furniture and appliances should be equipped with non-staining large surface floor protectors.
- When moving appliances or heavy objects over the flooring, ensure that sliding pads or protective blankets are used as damage caused by appliances is not covered under warranty.
- When moving appliances or heavy furniture it is always wise to lay a plywood panel, or similar, on your floor and “walk” the item across it. This protects your floor from scuffing, gouging and damage.
- Furniture with castors or wheels must swivel easily and be suitable for resilient floors. Do NOT use ball type castors as they can damage the floor. Caster wheeled chairs should have wide, rubber casters. Place protective mats under office chairs.
- Use floor protectors under furniture to reduce indentation. As a general rule of thumb, the heavier the item, the wider the floor protector should be.
- Do not allow standing water to remain on the surface of your flooring. Although your flooring is 100% water proof, standing water can seep into the sub-floor through the seams in the flooring causing issues with the adhesive and mildew within the sub-floor.



### Ultra Smooth Non-Textured



Our MonoCore™ Products are designed to give you the ultimate bold and vivid colors, our super flat, matte flooring will not hide micro-abrasions or scuffs.

## Part 3. Warranty Information

Lucida Surfaces® Limited Residential Warranty

**25-year for MaxCore™, TerraCore™, and DecoCore™ products and 10-year for CliCore™ and MonoCore™ products.**

Lucida Surfaces® LLC ("Lucida") provides the following limited 25-year or 10-year residential warranty to the original purchaser for as long as he or she owns the flooring product and uses it under normal conditions:

The MaxCore™ surface will not wear through;

The planks will not fade due to sun or electrical light;

The planks will not stain under normal conditions;

The planks will resist damage from moisture due to damp mopping and everyday spills;

The unilin™ locking joint will remain secure under normal use conditions.

The Limited Warranty does not cover discoloration from mold or from flooding, floods, leaking plumbing or appliances, water entering through sliding glass doorways, as well as floor covering failure due to hydrostatic pressure or moisture vapor emission.

This limited warranty is subject to the conditions described in the "Conditions" section below and does not apply if used in any commercial setting.

Lucida Surfaces® Limited 6-Month Manufacturing Warranty

Lucida Surfaces® provides a limited warranty to the original purchaser for six (6) months from the date of purchase covering any manufacturing defects in the flooring product. The Lucida Surfaces® Limited 6-Month Manufacturing Warranty is made subject to the following condition:

This limited warranty does not cover any damage that occurs during shipment or installation.

Lucida Surfaces® Limited Light Commercial Warranty

**10-year for MaxCore™, TerraCore™, and DecoCore™ products and 5-year for CliCore™ products.**

Lucida Surfaces® provides the following limited light commercial warranty to the original purchaser for 10 years or 5 years from the date of purchase that:

The MaxCore™ surface will not wear through;

The planks will not fade due to sun or electrical lights; and

The planks will not stain.

This limited warranty is subject to the conditions described in the "Conditions" section below and only applies if used in one of the following commercial areas:

Retail:

Entryways\*, Sales Floor/Showroom, Checkout, Breakrooms, Dressing Rooms, Offices, Storage Rooms.

Doctor's Offices:

Entryways\*, Lobbies, Waiting Rooms, Hallways, Nurses Stations, Offices, Breakrooms, Storage Rooms.

Hotels:

Entryways\*, Lobbies, Hallways, Guest Rooms, Conference/Meeting Rooms, Kitchenettes, Lounges, Offices.

Business Offices:

Entryways\*, Lobbies, Hallways, Offices, Conference/Meeting Rooms, Breakrooms. Restaurants: Entryways\*, Lobbies, Hallways, Offices.

Educational:

Entryways\*, Lobbies, Hallways, Offices, Classrooms, Storage Rooms, Residence Halls, Common Areas.

Multi-family Housing:

Entryways\*, Lobbies, Common Areas, Hallways, Offices, Storage Rooms, Individual Housing Units.

\*Walk off mats are required at all entryways

All areas must be assessed prior to installation of flooring to determine if other surface measures need to be taken or conditions addressed, including, but not limited to requirements for static control, state health and building codes, slip resistance, high

impact traffic and moisture/water exposure. Other than the specific warranty identified above, Lucida Surfaces® provides no additional warranties and Lucida Surfaces® does not warrant that any of the uses identified above are in compliance with any applicable building, health, inspection, and/or other municipal regulation or codes. Lucida Surfaces® is not responsible for usage that is not in compliance with any regulation or code. Proper assessment of location and usage must be applied. Contact your Lucida Surfaces® representative for questions on performance in specific locations. The Lucida Surfaces® Limited 25-Year Residential Warranty and Limited 10-Year Light Commercial Warranty are made subject to the following conditions:

The planks must be installed properly in accordance with Lucida Surfaces® installation instructions. The instructions should be obtained through a retailer or at [www.LucidaSurfaces.com](http://www.LucidaSurfaces.com). Proper installation includes, but is not limited to, the following:

A moisture test must be performed to determine if excessive moisture exists in the subfloor.

When installing over concrete, a calcium chloride moisture test must be performed. Readings greater than 5 lbs/1,000 sq. ft./24 hours are unacceptable for installation. If a moisture meter is used, a reading greater than 4.5% is unacceptable.

A polyethylene film vapor barrier must not be used over wood subfloors. Moisture readings of wood subfloors must not exceed 14% throughout the entire installation.

Foam underlayment must meet or exceed 2.0 lb polyethylene foam (1.9-2 lb density), CFC Free, 1.8mm to 2.1mm thickness.

When installing Lucida Surfaces® in special situation areas such as terrazzo, pier and beam or radiant heating and to also learn how to properly acclimate your floor, please contact our consumer help line at USA - 1.845.877.7008 or Canada - 1.514.587.9926 or visit [www.LucidaSurfaces.com](http://www.LucidaSurfaces.com) to obtain important additional information. The flooring must be used indoors only in a dry, climate-controlled area.

The flooring must be maintained in accordance with Lucida Surfaces® care and maintenance instructions.

Damage must not have occurred as a result of improper or inadequate maintenance or accidents, such as damage caused by scratching, impact or cutting. Damage resulting from the use of a jet mop, spray mop, or similar wet mop with the flooring is not covered by this limited warranty.

Surface wear must be readily visible (i.e. approximately 1 square inch). Gloss or sheen reduction is not surface wear and is not covered by these limited warranties.

These limited warranties do not apply to water damage, including but not limited to water damage caused by flooding, standing water (water that remains on planks longer than 30 minutes), leaking pipes, mechanical failures, appliance leaks or pet urine.

These limited warranties do not apply to damage caused by water or moisture in the subfloor or underneath the flooring, including but not limited to damage from subfloor hydrostatic pressure (water or moisture under the planks that is transmitted to the surface through exerted pressure) or other conditions that result in water or moisture being below the floor.

In order to retain the MaxCore® 100% water resistant feature, cut planks must be resealed with silicone sealant.

These limited warranties do not apply to flooring installed on a concrete subfloor unless a non-recycled (100% virgin resin) 6-mil

polyethylene film vapor barrier with a density of 0.92 lbs/cubic foot and a thickness tolerance of +/- 10% is installed over the concrete subfloor that emits a water vapor no greater than 5 lbs. per 1,000 sq. ft. within 24 hrs.

These limited warranties do not apply to moldings.

Installation of flooring that contains any manufacturing defect is not covered by these limited warranties.

#### How to Make Claims

Any claim under any of the limited warranties above must be made by contacting your retailer within 30 days after the basis for the claim is detected. In addition, any claim under any of the limited warranties above must be made before the end of the applicable limited warranty period. Proof of purchase, including the date of purchase, must be presented to make a claim.

#### Lucida Surfaces® Responsibility

If Lucida Surfaces® accepts a claim under any of the limited warranties above, Lucida Surfaces® will repair or replace, at its option, the affected Lucida Surfaces® flooring material only. If Lucida Surfaces® in its sole discretion determines that such repair or replacement is not reasonably achievable, Lucida Surfaces® may choose to refund the purchase price of the affected Lucida Surfaces® flooring material. If the design for which a claim is made is no longer available, Lucida Surfaces® will replace the affected planks materials with another Lucida Surfaces® design of equal or greater value at Lucida Surfaces® discretion. Upon approval of the warranty claim, Lucida Surfaces® will provide you with instructions on the manner in which to proceed in order to have your flooring repaired or replaced, and you must comply with such instructions within ninety (90) days after the claim is approved or your rights under the limited warranty will be deemed waived. The above remedies are the sole and exclusive remedies for claims on this product. These limited warranties give you specific legal rights, and you may also have other rights which vary from State to State.

#### Disclaimers

LUCIDA SURFACES® DISCLAIMS ALL OTHER EXPRESS OR IMPLIED WARRANTIES, INCLUDING ANY IMPLIED WARRANTY OF MERCHANTABILITY OR FITNESS FOR A PARTICULAR PURPOSE, WITH RESPECT TO THIS PRODUCT.

Lucida Surfaces® disclaims liability for incidental and consequential damages. Some States do not allow the exclusion or limitation of incidental or consequential damages, so the above limitation or exclusion may not apply to you.

These limited warranties are not transferable. They extend only to the original end consumer.

Samples, descriptions, and other information concerning the product contained in Lucida Surfaces® catalogs, advertisements, or other promotional material or statements made by sales representatives or distributors are for general informational purposes only and are not binding upon Lucida Surfaces®. No sales representatives or distributors shall have any authority whatsoever to establish, expand or otherwise modify Lucida Surfaces® warranties.

The provisions of these limited warranties are deemed to be severable and the invalidity or unenforceability of one provision shall not affect the validity or enforceability of any other provision. These limited warranties constitute the entire agreement of the parties, and no waiver or amendment shall be valid unless in writing and signed by an authorized representative of Lucida Surfaces®.



## **Lucida Surfaces USA**

55 Haul Road  
Wayne, NJ 07470  
1-845-877-7008

## **Lucida Surfaces Canada**

8620 Rue Pascal-Gagnon  
Montreal, QC H1P 1Z1  
1-514-587-9926

[sales@lucidasurfaces.com](mailto:sales@lucidasurfaces.com)

[www.LucidaSurfaces.com](http://www.LucidaSurfaces.com)